



Supplying Hospitals
for Over 90 Years

User Guide

MDS86835

Deluxe Rolling Walker



Contents

Deluxe Rolling Walker Features	3
Walker Components	4
Safety Instructions	5
Assembly Instructions	6
Rear Wheel Assembly	7
Front Wheel Assembly	8
Brake Handle Assembly	9
Backrest Assembly	10
Cup Holder Assembly	11
Operating Instructions	12-13
Maintenance	14
Warranty	15

Deluxe Rolling Walker Features

Congratulations on purchasing one of the most durable walkers made anywhere. With proper assembly, the walker will provide years of great performance.



Hand brakes push to lock, pull to release.



Includes high-end, water-proof nylon bag with snaps. Shoulder strap gives end-user more freedom.



Height/seat adjustable legs and handles with easy to read numbered holes.

- Weighs only 16.5 lbs (7.5 kg)!
- Height adjustable (junior-standard)
- Removable nylon carry-all bag
- Hand brakes lock for safety
- 7" (17.8 cm) wheels for smooth ride
- Swivel front wheel for easy maneuvering

Height Measurements

- Seat height adjustable from 19" to 23.25" (48.2 to 59 cm)
- Handle height adjustable from 30.5" to 37.25" (77.5 to 94.6 cm)

Walker Components

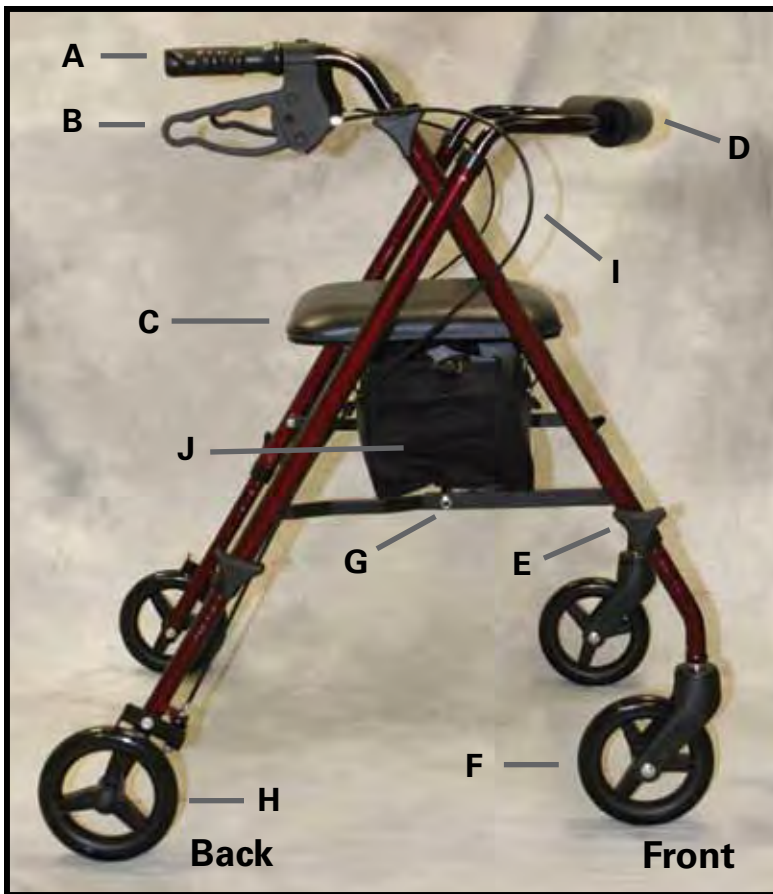

Figure 1

Assembled Deluxe Rolling Walker

- A.** Hand Grips
- B.** Hand Brake Lock
- C.** Padded Seat
- D.** Padded Backrest
- E.** Triangular Hand Screw
- F.** 7" (17.8 cm) Front Wheels
- G.** Folding Hinge
- H.** 7" (17.8 cm) Rear Wheels
- I.** Brake Cable
- J.** Bag with Shoulder Strap



Figure 2 (E)
Triangular Hand Screw



Figure 3 (A & B)
Hand Grip & Brake

Safety Instructions

To ensure your safety in using the Medline walker, the following safety information and all instructions must be followed.

- **DO NOT** use this product without first reading and understanding the instructions contained in this booklet. If you are unable to understand the warnings, cautions, or instructions, contact a healthcare professional, dealer, or technical personnel before use—otherwise serious bodily injury and damage may occur.
- Consult with your doctor, physical, or occupational therapist or other qualified professional to assure the proper height adjustment.
- Walkers are for individual use only and are **NOT** to be used as a wheelchair.
- **DO NOT** attempt to move the walker while you or anyone is sitting on the seat.
- **DO NOT** self-propel the walker while seated.
- Serious injury to you and/or damage to the walker frame or wheels may result from improper use.
- **DO NOT** use the seat to transport people or objects. **DO NOT** use the seat to carry or move anything.
- **DO NOT** sit on the walker while it is being loaded into a vehicle or while it is being transported in a vehicle.
- **DO NOT** exceed the maximum weight capacity (including bag contents) or serious injury could result: **Maximum weight capacity: 300 lbs (136 kg)**
- Before each use make sure the walker frame is fully opened.
- Check the brakes for proper operation. Make sure that all parts are secure and that moving parts are in good working order. Wheels should roll and not wobble.
- All wheels must be in contact with the floor and/or ground at **ALL TIMES**. This will ensure the walker is properly balanced.
- The brakes **MUST** be in the locked position **BEFORE** sitting on the seat.
- **DO NOT** sit on the seat when the walker is on an incline.
- **DO NOT** use the walker to walk backwards, down gradients or to climb stairs, curbs, or to go over obstacles. Serious risk of fall or injury may occur.
- **DO NOT** perform any adjustments to the walker while it is in use.
- Only use accessories and spare parts authorized by Medline Industries, Inc.
- **DO NOT** push walker while brakes are enabled. Brakes are used to keep the wheels from rolling; but it may not prevent the walker from moving if it is pushed.
- **DO NOT** use the walker to provide assistance while rising from a lower position. If you use it to pull yourself up to a standing position, the walker may move even if the brakes are in the locked position and this could result in a fall.
- Inspect the handle bar grips prior to use. Assure the plastic parts are still functional if they are exposed to extreme temperatures (above 100°F (38°C) or below 32°F (0°C) high humidity and/or become wet. **DO NOT** twist hand grips as they are not meant to be twisted. Failure to do this could result in a fall.
- **DO NOT** hang anything from the frame of the rolling walker other than the basket included or the tote bag accessory. The basket has a weight limitation of 11 lbs (5 kg). The tote bag has a weight limitation of 10 lbs (4.5 kg). Items should be placed completely in the basket or tote bag and should not protrude. This may cause the walker to tip, resulting in bodily injury or walker damage.
- The backrest is intended to provide back support as you sit on the seat. The backrest is not intended to support full weight. Avoid leaning while sitting as this may result in fall.
- **DO NOT** use the walker as a wheelchair.

Assembly Instructions

IMPORTANT: Read all operating and safety instructions before using your Medline Deluxe Rolling Walker.

1. Carefully remove the walker components from the shipping carton. Refer to diagram (Figure 1) as needed.
 - 1 Walker Frame
 - 6 Triangular Hand Screws
 - 1 Bag with Shoulder Strap
 - 2 Front Wheels
 - 2 Rear Wheels
 - 1 Backrest with Push-Buttons
 - 2 Hand Grips with Brake Assembly
2. Examine all parts for shipping damage. **DO NOT** use the walker if there is apparent damage or if any parts (other than the bag) are missing. If there are missing or damaged parts, please call Medline Customer Care toll free at 1-800-MEDLINE.
3. Check all of the wheels to see that they are in good working order and roll freely. Remove plastic cover from the wheels before use.
4. Unfold the Medline walker by pushing down on the Folding Hinge (G) until the frame is in full extension.



Rear Wheel Assembly

1. Turn wheel so that it is facing outside of walker (**see Figure A**).
2. Insert wheel to desired height depicted by numeric holes (**see Figure B**) and use chart below for recommended height settings.
3. Insert triangular hand screw into hole on same side of wheel so that the triangular hand screw stays outside of walker frame (**see Figure C**).
4. Tighten triangular hand screw (**Important: Hand Tighten Only!**) until secure (**see Figure C**).
5. Repeat steps 1-4 for other rear wheel.

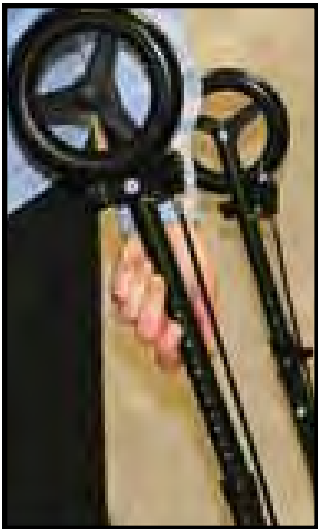

Figure A



Figure B



Figure C



Recommended Height:

Your feet should comfortably touch the ground when you are seated on walker.

Height Range:

Under 5' (152 cm)	Hole 1 or 2
5'1"-5'6" (155-170 cm)	Hole 3 or 4
5'7" (173 cm) and over	Hole 5 or 6

Note: These are only recommended heights, as each individual is built differently.

Front Wheel Assembly

1. When inserting front wheel, make sure FRONT sticker is pointed toward the front and away from walker (**see Figure A**).
2. Insert wheel to desired height depicted by numbered holes (set to the same number as rear wheels) (**see Figure B**).
3. Place triangular hand screw into hole. Make sure triangular hand screw stays outside of walker frame (**see Figure B**).
4. Tighten triangular screw (**Important: Hand Tighten Only!**) until secure (**see Figure C**).
5. Repeat steps 1-4 for other front wheel.



Figure A



Figure B



Figure C



Brake Handle Assembly

1. Insert hand grip into appropriate hole **(see Figure A and chart below)**.
Note: Keep brake cable on outside of walker.
2. Insert triangular hand screw into hole on outside of walker frame **(see Figure B)**.
(Important: Insert hand screw into one of the 4 holes provided. DO NOT put hand screw in open slot at end of hand grip!)
3. Hand tighten screw until secure **(see Figure C)**. **(Important: Hand Tighten Only!)**
4. Repeat steps 1-4 for other hand grip.

Deluxe Rolling Walker Hole Measurements:

Arm Height

	Hole 1	Hole 2	Hole 3	Hole 4
Leg Height	Hole 1 30.50" (77.5 cm)	Hole 2 31" (78.7 cm)	Hole 3 32" (81.3 cm)	Hole 4 33" (83.8 cm)
	Hole 2 31.50" (80 cm)	Hole 3 32" (81.3 cm)	Hole 4 33" (83.8 cm)	Hole 5 34" (86.4 cm)
	Hole 3 32.50" (82.6 cm)	Hole 4 33.75" (85.7 cm)	Hole 5 34.75" (88.3 cm)	Hole 6 35.75" (90.8 cm)
	Hole 4 33.25" (84.5 cm)	Hole 5 34.50" (87.6 cm)	Hole 6 36.25" (92.1 cm)	
	Hole 5 34" (86.4 cm)			
	Hole 6 34.75" (88.3 cm)			



Figure A



Figure B



Figure C



Seat height adjustable from 19 to 23.25" (48.2 to 59 cm)
Handle height adjustable from 30.5 to 37.25" (77.5 to 94.6 cm)

To determine proper height, stand upright behind the walker with shoulders relaxed, arms hanging at your side and eyes looking straight ahead. Standing in current position, the hand grips (A) of the walker should be adjusted to a height even with the wrists. This will position the arms at an approximated 20 to 30 degree bend when using the walker. Secure the wheels to the closest hole to the desired height. Insert and tighten the triangular hand screws until secure.
(Important: Hand Tighten Only!)

Backrest Assembly

1. Insert backrest into designated slot so that push-buttons are facing outward (**see Figure A**).
2. Push buttons in and continue to insert backrest until buttons securely lock into holes (**see Figure B**). **Please note:** There are 2 positions for the back rest. Adjust according to your preference, but make sure both push buttons are protruding and at the same level.

Notes: Make sure the brakes are locked **before** you lean against backrest. Make sure push-buttons are completely protruding **before** leaning against backrest.



Figure A



Figure B



Figure C

Cup Holder Assembly

1. Make sure you have all the necessary pieces.

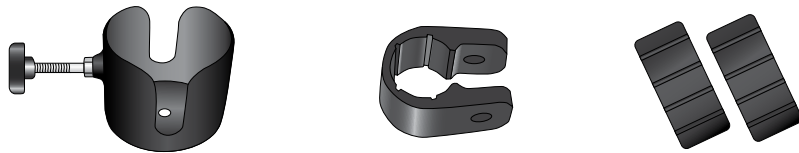

Cup Holder with Star Knob U-Shaped Clamp 2 Scored Rubber Sleeves

2. Snap U-shaped clamp onto the tubing of your mobility device (see **Figure A**).

Note: Be sure the clamp is positioned in such a way that it allows the cup to sit level, **NOT** tilted in a direction that might allow your drink to spill (see **Figure B**).

3. Remove the star-shaped knob from the cup holder, insert holder through the opening in the clamp, and tighten the knob to assure that the cup holder stays tightly attached (see **Figures C and D**). (**Important: Hand Tighten Only!**)

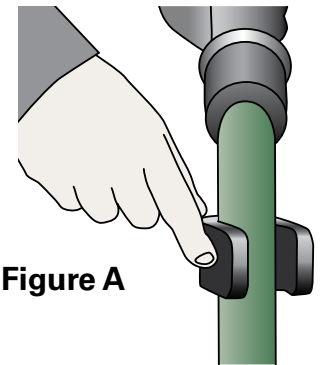

Figure A



Figure B

Figure C

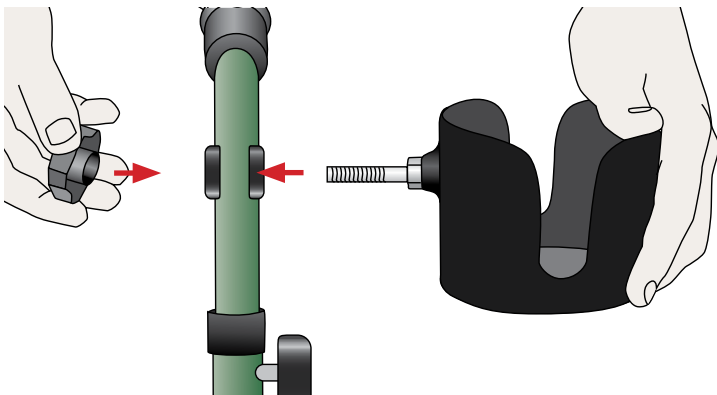
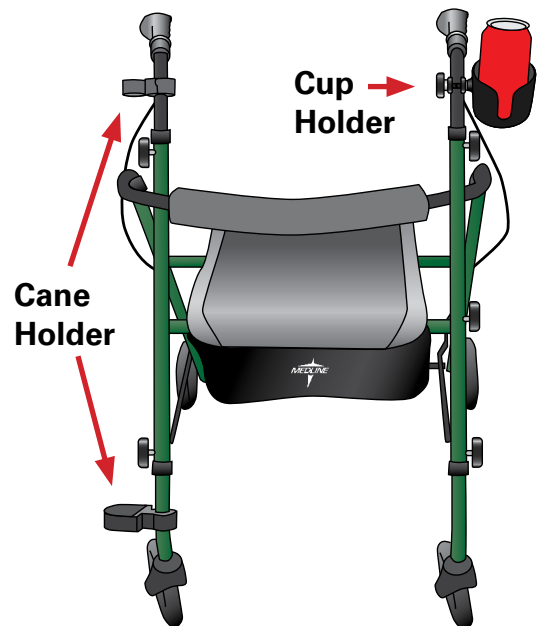
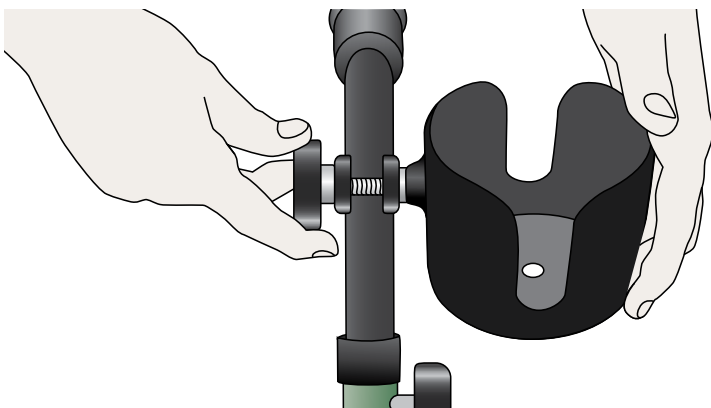

Figure D



Note: If necessary, insert a rubber sleeve in the clamp to better fit the size of the tubing. Whether you use a sleeve or not, the clamp should fit tightly onto the tubing, otherwise the cup holder is susceptible to slipping and spilling your drink, which may cause injuries.

Enjoy your drink on the go!

Operating Instructions

Opening the Walker

Push down on the seat **(C)** until all four wheels are extended out and the seat is completely flat. Before using the walker make sure that all four wheels make contact with the floor and the walker is stable in the open position.



Folding the Walker

- For more compact storage, remove bag and the backrest.
- Pull up on the bar under the seat until the walker closes.

Checking the Brakes

- Before each use, check to make sure the brakes are working properly.
- Applying pressure on the brake handles by squeezing the brake up, will stop the wheels momentarily.
- Pushing down on the brake handles will lock the wheels in place permanently.



Adjusting the Brakes

1. Loosen the cable nut.
2. While holding the brake down onto the wheel, pull down on the brake cord to lengthen the brake cable.
3. Retighten the nut. Retest and repeat as necessary for good brake function.

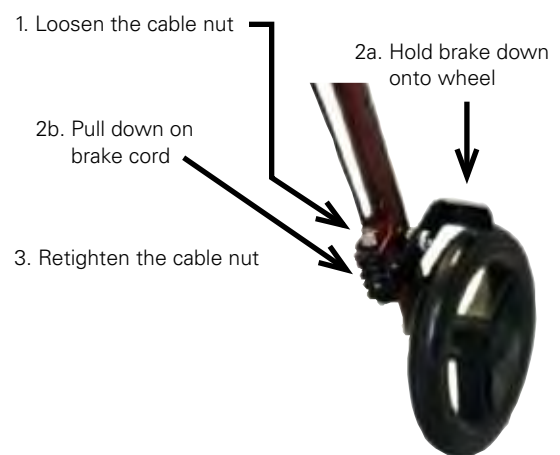

Operating Instructions

Using as a walker:

For proper positioning and use of your walker, imagine a line drawn across the back of the rear wheels. Part of one foot should be slightly ahead of that line as you walk.

Using as a seat:

- Push the walker into the position where you want to sit.
- **LOCK** the brakes **BEFORE** sitting.

To Operate the Brakes:

- To slow down, squeeze the brake handles up.
- To lock the brakes, push down on the brake handles until you feel or hear the brakes click into locked position. If the brakes have been adjusted but the rear wheels on the walker move while the brakes are in the locked position, **DO NOT** use the walker. Please call our toll-free customer service number at 1-800-MEDLINE for returns or repairs.
- To release the brakes from the locked position, simply pull up on the brake handles.

Safety Warnings: Also See Safety Instructions

Before using the seat portion of your walker, **ALWAYS** lock the brakes **FIRST**. **DO NOT** navigate the walker while sitting on the seat. The brakes should always be locked when the seat is being used. Risk of fall and serious injury may result if brakes are **NOT** locked while the user is sitting on the seat.

Maintenance

Your Medline walker should be checked periodically to ensure the brakes are functioning properly and that all nuts and bolts are secure.

Periodically test the brakes by both walking and squeezing the brakes and by stopping, pushing down on the brakes to a locked position, and then trying to push the walker. If the brakes do not lock the wheels, the brakes need to be adjusted. If adjustment does not tighten the brakes, **DO NOT** use the walker.

Keep your receipt!

Contact us at 1-800-MEDLINE, Monday – Friday 8am to 5pm CST if you encounter any problems or for information regarding repairs or maintenance.

Lifetime Limited Warranty

Your Medline walker frame is warranted to be free of defects in material and workmanship for a lifetime for the original consumer. This device was built to precise standards and carefully inspected prior to shipment. This Lifetime Limited Warranty is an expression of our confidence in the material and workmanship of our products and assures years of convenient, dependable service. In the event of a defect covered by this warranty, we will, at our option, repair or replace the device.

This warranty does not cover device failure due to owner misuse, negligence, or normal wear and tear. The warranty does not extend to non-durable components such as plastic accessories, brakes and grips, which are subject to normal wear and replacement. Non-durable components are warranted for 6 months. If you have a question about your Medline product or this warranty, please call us at 1-800-MEDLINE. This warranty gives you specific legal rights, and you may have other rights, which vary from state to state.

LIFETIME WARRANTY	6 MONTH WARRANTY
<i>FRAME</i>	<i>HAND BRAKES BRAKE CABLES PUSH-BUTTONS BACKREST BRAKES UPHOLSTERY WHEELS (FRONT AND REAR) MEDLINE BAG TRIANGULAR HAND SCREWS ALL OTHER PARTS</i>



Medline Industries, Inc.

One Medline Place
Mundelein, IL 60060

Medline United States
1-800-MEDLINE (633-5463)
www.medline.com | info@medline.com

Medline Canada
1-800-396-6996
www.medline.ca | canada@medline.com

Medline México
01-800-831-0898
www.medlinemexico.com | mexico@medline.com

Some products may not be available for sale in Mexico or Canada. Please contact your Account Representative for additional information.
We reserve the right to correct any errors that may occur within this manual. ©2009 Medline Industries, Inc. Medline is a registered trademark of Medline Industries, Inc.